

# HF-2 MAX<sup>®</sup>

Emergency Assistance Lighted Tower



INSTALLATION

and

OPERATIONAL INSTRUCTIONS

 **TRIGON**<sup>®</sup>  
ELECTRONICS, INC.

255 Glider Circle • Corona, CA 92880  
(800) 842-7444 • [Info@trigonelectronics.com](mailto:Info@trigonelectronics.com)  
[www.TrigonElectronics.com](http://www.TrigonElectronics.com)

March 1, 2004

---

**TABLE OF CONTENTS**

---

**INTRODUCTION** ..... 3

**PRODUCT OVERVIEW** ..... 3

**INSTALLATION** ..... 4

**WIRING** ..... 4

**FOUNDATION DIAGRAM** ..... 5

**BASEPLATE DIAGRAM** ..... 6

**PROGRAMMING**

    Entering Program Mode ..... 7

    Setting Operational Modes ..... 7

    Entering Autodialed Telephone Numbers ..... 7

    Verifying Autodialed Telephone Number ..... 7

    Setting the Site ID Number ..... 8

    Changing Program Access Number ..... 8

    Setting the Relay Duration Timer ..... 8

    Setting Incoming Ring Count ..... 8

    Setting Dial Mode ..... 8

    Setting Call Length ..... 8

    DTMF Echo Test ..... 8

    Cycling Relays ..... 8

**OPERATION**

**STANDARD** Mode ..... 9

**OPTIONAL** Mode ..... 9

**TROUBLE SHOOTING GUIDE**

    General ..... 10

**CONDENSED GUIDE TO USE and PROGRAMMING**

    Security Dept. Operation ..... 11

    Standard Mode ..... 11

    Optional Mode ..... 11

    Programming the Unit ..... 11

## INTRODUCTION

This manual contains all the information required to install and program the TRIGON HF-2MAX. If you are using this manual to install this unit, it is very important to read all the sections in order.

You should read these instructions before you begin installation. This will insure that everything is done efficiently.

If you are using this manual as a programming guide after the initial installation, you may find the TABLE OF CONTENTS useful in locating the particular programming procedure you need.

## PRODUCT OVERVIEW

The TRIGON HF-2 MAX is a multi-number Emergency auto dialer housed in an 8' 6" steel tower.

The HF-2 MAX comes standard with 1 output relay. An optional second relay is also available and can be programmed to operate in several different ways. It can be set to pulse momentarily for camera call-up, or it can be set to operate for a timed duration.

There are two Modes of Operation incorporated in the HF-2 MAX:

### 1. Standard Emergency Mode:

When the call button is pressed, the unit engages its primary relay for the duration of the call, activating the emergency strobe light. The HF-2 MAX begins dialing according to its programming ( up to 10 number rollover). This call may only be terminated only by the called party. If the number dialed is busy or does not answer, the HF-2MAX will hang up and dial the next programmed number, up to a maximum of 10. If the last programmed number is busy or does not answer, the HF-2 MAX will rollover and start the dialing process again with the first phone number. The Standard emergency mode is set to utilize "Called Party Disconnect". The HF-2 MAX will hang up within 8 seconds after the called party hangs up.

### 2. Optional Ring Down Mode:

When call call button is pressed, the unit engages its primary relay for the duration of the call, activating the emergency strobe light. The HF-2 MAX seizes the telephone line and waits for the PBX to dial a preprogrammed number. This call may only be terminated by the called party. The optional ring down mode is set to utilize "Called Party Disconnect". The HF-2 MAX will hang up within 8 seconds after the called party hangs up.

A Site I.D. code feature provides for unit identification. The Site I.D. code is a programmable four digit code that is transmitted by the HF-2 when it receives a command from the called party. This code, when interpreted by a Trigon DTMF Decoder, will identify the calling unit.

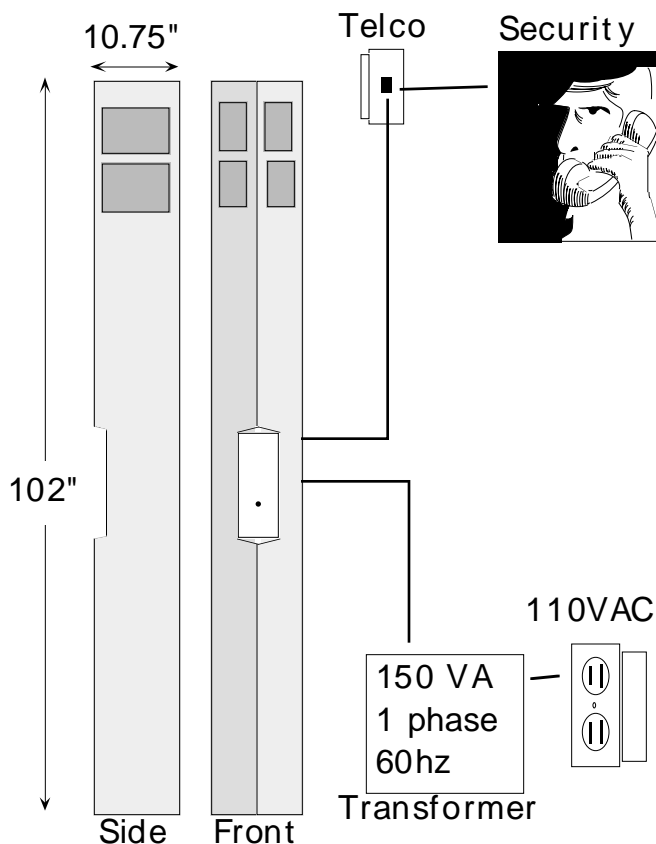

Figure 1

---

## INSTALLATION

---

### Foundation

**1. Conduit:** Electrical and telephone line conduit, with a maximum combined diameter of three (3) inches, should be run up through the center of the foundation hole. A minimum of four (4) inches and a maximum six (6) inches of conduit above the finished grade level is required.

**Note:** Follow all national and local codes governing this installation.

**2. Pour the Foundation:** The foundation should be at least 24 inches in diameter, and to the correct depth for the frost in your area. with a minimum depth fo at least three (3) feet.

**3. Setting anchor bolts in the foundation:** An aligning template is supplied for positioning the anchor bolts of the HF-2 MAX. Three (3) 24-inch L-shaped anchor bolts should be set into the foundation so that six (6) inches are left showing above the finished grade level. The anchor bolts should be aligned using the supplied template, in such a way that the phone faceplate on the unit will face in the desired direction.

### Mounting the HF-2 MAX

**1. Attaching nuts and washers to anchor bolts:** After the foundation has set, screw one set of nuts followed by one set of washers onto the anchor bolts. Set the nuts such that the lowest washer is about 2.5 inches

above the concrete and at an even height. To accomplish this, use a small level and check from front to back, side to side, and diagonally ( Note: These nuts ar NOT adjustable after the unit is in place). The bottom of the HF-2 MAX should be .75 inches above the concrete when properly installed.

**IMPORTANT:** Levelling of the bottom nuts is crucial to the leveling of the unit. Any small error will be magnified greatly at the units top. A .75 inch minimum air gap is required between the foundation and the base of the unit. Moisture problems may result if this condition is not complied with.

**Note:** Follow all national and local codes governing this installation.

**2. Mounting the HF-2 MAX:** Align the phone plate in the desired direction, and then lift the HF-2 MAX over the anchor bolts using the mounting brackets.

**Caution:** The unit weighs approximately 220 lbs. Use appropriate lifting materials and methods to avoid possible injury and / or damage.

**3. Securing the HF-2 MAX:** Access the mounting bolts through the backside of the HF-2 MAX, and tighten the nuts to the mounting bolts. Torque the nuts to approximately 20 foot pounds.

---

## WIRING

---

1. Use the wiring diagram (Fig. 3) for wire connection information.
2. Do not power any other device from the Trigon's 12 VAC transformer. If a substitute transformer is used, be sure it is rated 12 VAC, 40VA, UL Class 2 listed. The 12 VAC input power wires should be 18AWG, 600V, insulated wire. This should be sufficient for distances up to 200 feet.
3. Do not energize wires until installation is completed.
4. Ground the unit by attaching a separate 12 AWG ground wire to the ground location on the terminal block. This ground wire should go to a grounding rod or grounded metal conduit.
5. Trigon recommends that an EMI filter (Cornell-Dubilier Model APF 1021 or equivalent) be mounted between the 12 VAC transformer output and the unit. EMI/RFI filters are available from Trigon. Mount the filter as close to the unit as possible. Ground the filter to the same point as unit ground.
6. Shielded cable is recommended. Ground the shielding to the same point as the unit and filter. To

avoid ground loops, do not ground the shield at both ends. Use 600V insulated wire for this installation.

**7.** Isolate the Telco phoneline from 12 VAC power wires. This will prevent 60 Hz hum from occurring on the phoneline. Use 22 AWG wire on Telco line run distances of up to 2400 feet. Consult the factory for distances greater than 2400 feet.

**8.** If all wiring and grounding is completed, remount the faceplate.

Check Local Code Requirements

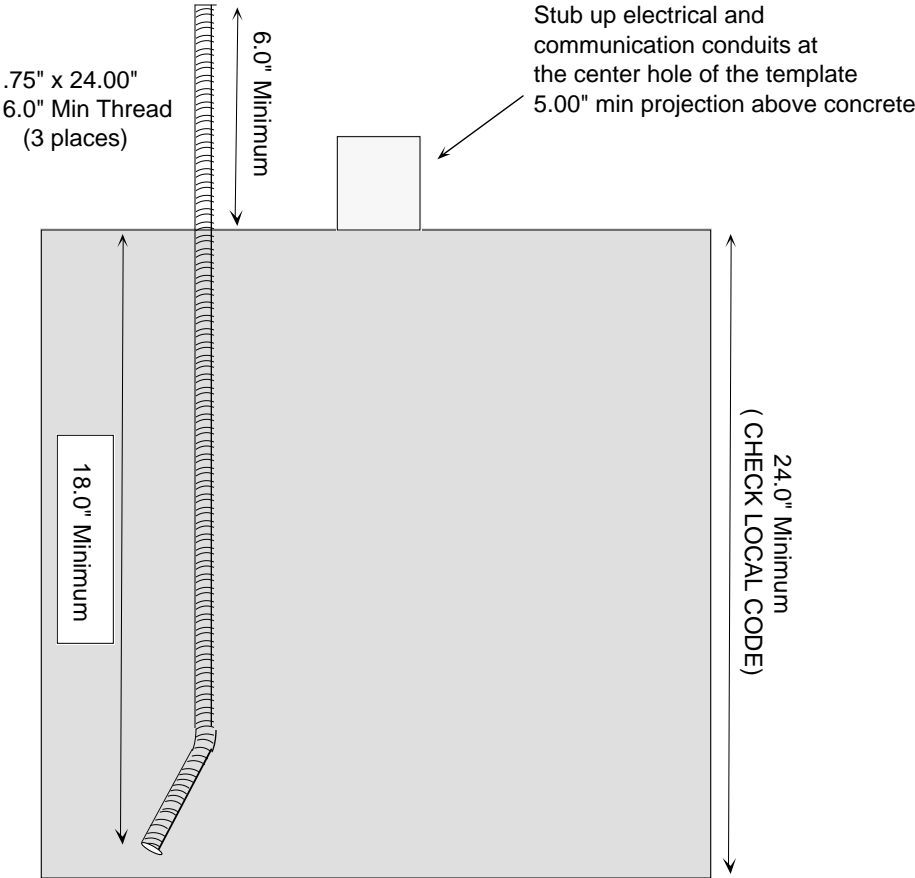

# MAX Tower Foundation

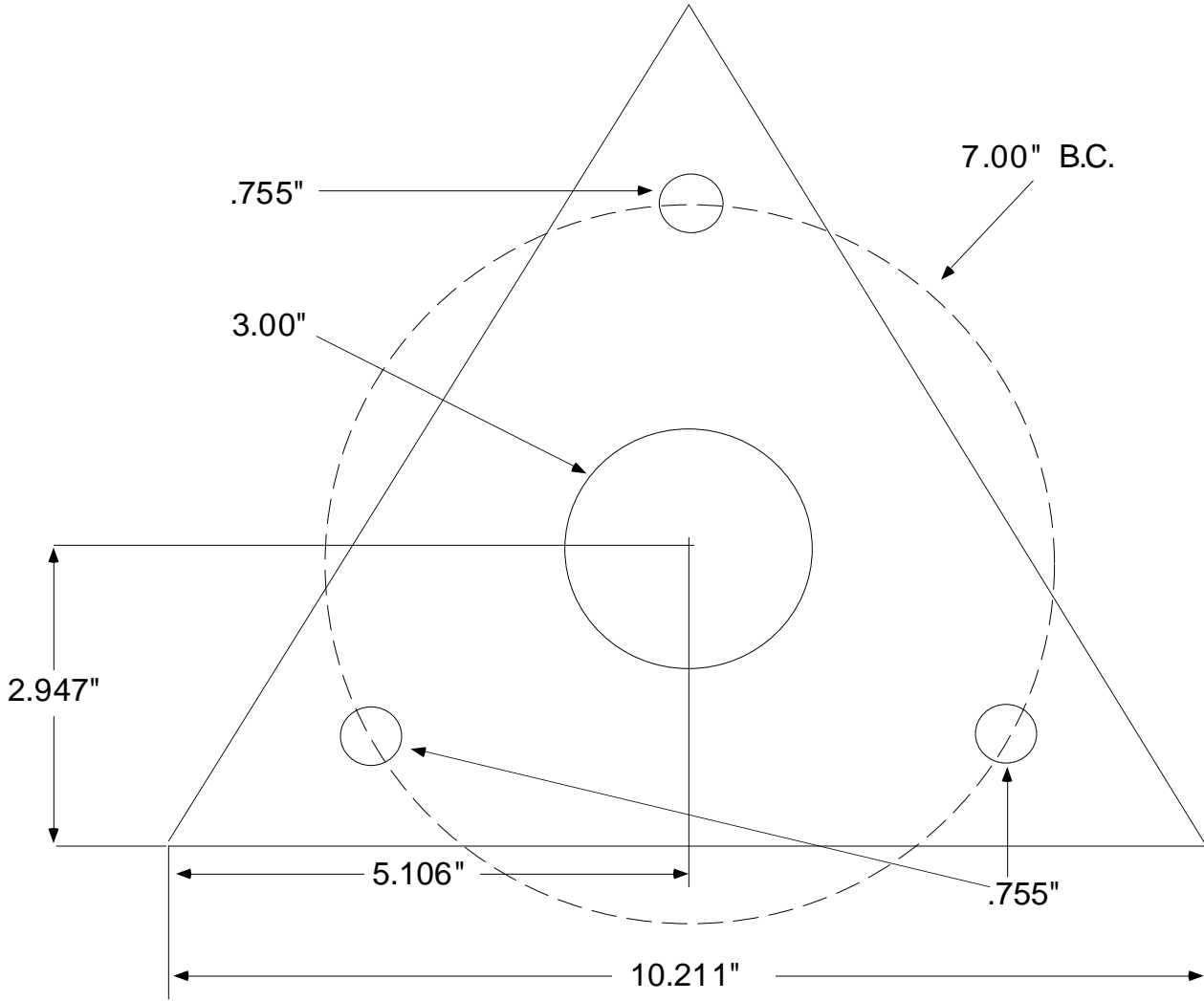

# MAX Tower Mounting Plate

**WIRING DIAGRAM**

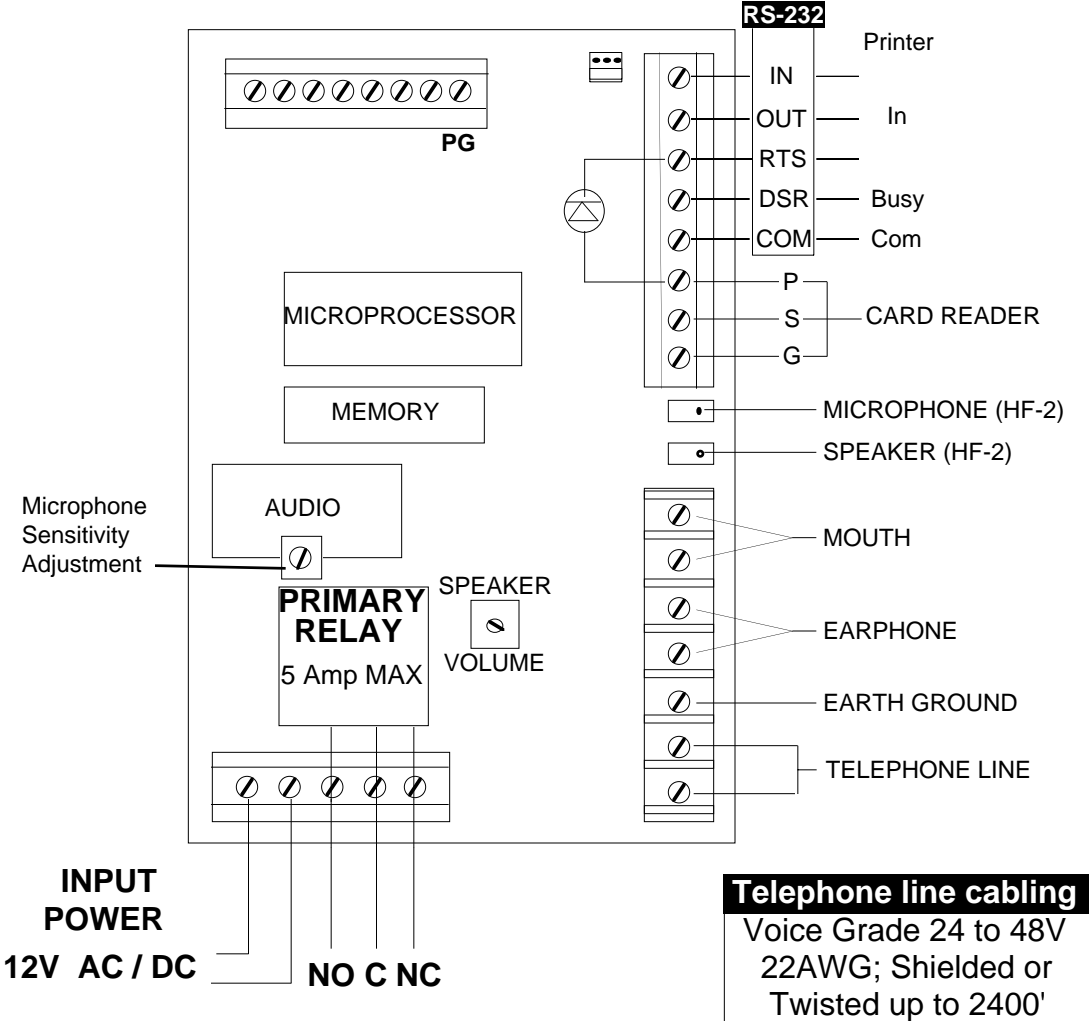

Input power cabling	
0-250'	18 AWG; Shielded
250 to 500'	16 AWG; Shielded
500' +	14 AWG; Shielded

**Telephone line cabling**  
 Voice Grade 24 to 48V  
 22AWG; Shielded or  
 Twisted up to 2400'

**TELALARM HF-2**

Figure 3

**PROGRAMMING INFORMATION**

**General Programming Information**

The "Initial Setup" for the HF-2 MAX has been programmed at the factory. These factory default settings may be changed to better suit your particular application. If you decide to alter these settings, follow the instructions below. It is important that each programming step be taken in order. When reprogramming a specific feature, you must always enter the programming mode first. You may then go to the appropriate procedural steps for the changes desired.

Record below the autodialed numbers to be programmed into the HF-2 MAX.

**Autodialed Numbers**

**Primary Auto dial Number (16 digit max)**

\_\_\_\_\_

**Second Auto dial Number (16 digit max)**

\_\_\_\_\_

**Third Auto dial Number (16 digit max)**

\_\_\_\_\_

**Fourth Auto dial Number (12 digit max)**

\_\_\_\_\_

**Fifth Auto dial Number (16 digit max)**

\_\_\_\_\_

**Sixth Auto dial Number (16 digit max)**

\_\_\_\_\_

**Seventh Auto dial Number (16 digit max)**

\_\_\_\_\_

**Eighth Auto dial Number (16 digit max)**

\_\_\_\_\_

**Ninth Auto dial Number (16 digit max)**

\_\_\_\_\_

**Tenth Auto dial Number (16 digit max)**

\_\_\_\_\_

**Site ID Number-if required Number (4 digits)**

\_\_\_\_\_

**PROGRAMMING**

**(A) To Enter Program Mode:**

1. Call the telephone number of the unit.
2. Listen for the two second tone.
3. Enter # then the unit's Program Code. If the unit is new, use the preset factory code. **(Factory code is 9753)**
4. If desired, exit Program Mode by pressing # (wait for two second tone).
5. To terminate call, press '7'.

**(B) Setting Operational Modes:**

**These settings determine how the HF-2 will function.**

Except when noted, each of the following program commands will result in two (2) tones (high/low) signifying their completion and acceptance.

*Optional Ring Down Mode* allows the HF-2 to operate as a ring down telephone on a PBX system where the PBX is programmed to call a specific number.

1. Unit must be in Program Mode.
2. Press '7' then press '4' to set unit for *Optional Ring Down Mode*.
3. If desired, exit Program Mode by pressing # (wait for two second tone).
4. To terminate call, press '7'.

*Standard Emergency Mode*, causes one relay to activate continuously throughout the call (for strobe illumination). The optional relay can be momentarily activated when a call is placed (for camera call-up).

1. Unit must be in Program Mode.
2. Press '7' then press '1' to set unit for *Standard Emergency Mode*.
3. If desired, exit Program mode by pressing # (wait for two second tone).
4. To terminate call, press '7'.

**(C) Setting the Primary and Backup Telephone Numbers:**

1. Unit must be in Program Mode.
2. Press '2' then '1' (wait for tone) and enter the first phone number. Press # when complete. Press '2' then '2' (wait for tone) and enter the second phone number. Press # when complete. If more numbers are needed press '2' then '3' (wait for tone) and so on for up to 10 phone numbers. Press # when complete.
3. If desired, exit Program Mode by pressing '3' (wait for two second tone).
4. To terminate call, press '7'.

**(D) Verifying Telephone Numbers:**

1. Unit must be in Program Mode.
2. Press '1' then press '1' to verify the first phone number entered.
3. Press '1' then press '2' to verify the second phone number entered etc.
4. If desired, exit Program Mode by pressing # (wait for two second tone).
5. To terminate call, press '7'.



## OPERATION

### STANDARD EMERGENCY MODE

When a CALL button is pressed, the HF-2 MAX activates the primary relay for the duration of the call, pulses the optional secondary relay for one second, dials a pre-programmed phone number, and monitors the line for the following signals:

**Busy Signal:** *The HF-2 MAX will hang up and redial the number after approximately three (3) busy tones.*

**Ring Signal:** *The HF-2 MAX will hang up and redial the number after approximately six unanswered rings (36 seconds).*

**Voice or Touch-tones:** *This indicates an answer. The unit then enters the Talk Mode.*

### Answering the Call From the HF-2 MAX

Answer the HF-2 MAX's incoming call with a short phrase **at least 3 seconds long**. The unit may fail to recognize a short greeting such as "Hello" and may not turn on the microphone.

Once voice communication has been established you may then press keys on your touch-tone telephone to do any of the following:

1. To **Deactivate** the **Optional Secondary** relay, press '0'.
2. To **Activate** the **Optional Secondary Relay**, press '5'.
3. To **Terminate** the **Call**, press '7'.
4. To **Reset** the HF-2 MAX's **Call Length Timer** for an additional 3 minutes, press '8'.

**Note:** The unit will beep twice to warn of auto-call termination in 10 seconds.

5. To **Toggle** on/off the **Primary Relay**, press '9'. The unit will respond with one tone to verify that the relay is deactivated, or two tones to indicate the relay has been activated.
6. To **Retrieve** the HF-2 MAX's **Site ID** number, press '\*'.
7. To **Enter** the **Program Mode**, press '#', followed by the four digit Program Code.

When the HF-2 MAX is in the Standard Mode, the call can only be terminated by the called party hanging up or when they press '7' on their telephone keypad.

**Note:** If the wrong Program code is entered, the unit will immediately hang up. If the program code or other information is not entered completely, the HF-2 MAX will time-out and hang up.

### OPTIONAL RING DOWN MODE

When a CALL button is pressed, the HF-2 MAX dials a PBX pre-programmed phone number:

**Voice or Touch-tones:** *This indicates an answer. The unit then enters the Talk Mode.*

### Answering the Call From the HF-2 MAX

Answer the HF-2 MAX's incoming call with a short phrase **at least 3 seconds long**. The unit may fail to recognize a short greeting such as "Hello" and may not turn on the microphone.

Once voice communication has been established you may then press keys on your touch-tone telephone to do any of the following:

1. To **Activate** the **Secondary Relay** and hang up after time-out, press '1' or '6'.
3. To **Terminate** the **Call**, hang up or press '7'.
4. To **Reset** the HF-2 MAX's **Call Length Timer**, press '8'.

**Note:** The unit will beep twice to warn of auto-call termination in 10 seconds.

5. To **Toggle** on/off the **Optional Secondary Relay**, press '9'. The unit will respond with one beep to indicate that the relay has been deactivated, or two beeps to indicate that the relay has been activated.
6. To **Retrieve** the HF-2 MAX's **Site ID** number, press '#'.

---

## **TROUBLE SHOOTING GUIDE**

---

### **NO DIAL TONE**

1. Check input power at unit. Should be 12 VAC.
2. Check that unit is properly grounded to a good Earth ground.
3. Current starved. Increase AC input wire size.
4. Remove power, wait 5 seconds, restore power. Check for dial tone.
5. Check for phone line. Should be 48-52 VDC across phone line terminals (on hook).
6. Check VOLUME adjustment on PC board.
7. Check "SPKR" plug on PC board. Make sure speaker is properly plugged in (Handsfree units).
8. Verify that contacts and wires are clean and tight.

### **CANNOT PROGRAM**

1. Incorrect/lost program code.
2. Not entering ' \* ' before program code.
3. Try 'NO DIAL TONE' troubleshooting procedures.
4. Keypad damaged. Check for vandalism.
5. Check that Program Prom/Microprocessor is fully seated.
6. Unit is in the wrong Operational Mode

### **LOSES MEMORY**

1. Electrical noise on power line. Install EMI/RFI filter.
2. Excessive electrical noise from strike. Use low current strike.
3. Unit transformer shared with another device (i.e. door strike).

### **RESIDENT CANNOT ACTIVATE STRIKE/GATE**

1. Tenant not pressing correct number on phone.
2. Strike/gate operator not wired correctly.
3. Missing or incorrect power to strike or gate operator.
4. Current starved. Increase wire size.
5. Tone may be too brief in duration (cordless phones, etc.).

### **AC HUM IN SPEAKER**

1. Phone wires running in same conduit as AC power.
2. Unit not properly grounded.
3. Defective microphone.

### **RESIDENT CANNOT HEAR VISITOR**

1. Defective handset/microphone.
2. Person receiving the call answers in too short a duration to activate the HF-2 (person must speak a minimum of 2 seconds to be detected).
3. Excessive background noise.

---

**CONDENSED GUIDE TO USE and PROGRAMMING**

---

**General**

Data between [ ] is a mandatory program key stroke sequence. Data between { } is to be supplied by the programmer. Unit responses are shown between ( ).

**Legend:**

d	Dial mode (0= Touch, 1= Rotary)‡	pppp	Program Code
f	Five second relay duration time (1, 2,...9)	r	Ring Count (1, 2, ...9)
iiii	Site ID number (always use four digits)	*	The “star” key of the telephone
lll	Call Length Time in seconds (001, ...999)	#	The “pound sign” key of the telephone
nnnnn	Phone Number (up to 12 digits)	☎	Tones returned by the unit

**SECURITY DEPT. OPERATION**

When Security personnel receive a call from the unit, they press key [X] on their telephone to:

**STANDARD MODE**

- [0] Deactivate Secondary (Camera) Relay
- [5] Operate Secondary (Camera) Relay
- [2] Factory Tone Test (answer tone)
- [7] Force disconnect (hang up)
- [8] Extends current Call Timer 3 minutes
- [9] Toggle on/off Primary Relay (☎ = off, ☎☎ = on)
- [\*] Requests Site ID Number
- [#{pppp}] Enter Program Mode

**OPTIONAL MODE**

- [0,5] Cycle Primary Relay
- [1,6] Cycle Secondary Relay
- [2] Factory Tone Test (answer tone)
- [7] Force disconnect (hang up)
- [8] Extends current Call Timer 3 minutes
- [9] Toggle on/off Secondary Relay (☎ = off, ☎☎ = on)
- [#] Requests Site ID Number
- [\*{pppp}] Enter Program Mode

**PROGRAMMING THE UNIT**

*Enter the Programming Mode: Call the unit, then press*

**[\*{pppp}] ☎☎**

[0{f}]☎☎ Set unit’s Gate Open time

[1{iiii}]☎☎ Set unit’s Site ID number

[2 then 1-0] ☎ [nnn nnn#] ☎☎ Set unit’s Auto dial numbers

[3{pppp}]☎☎ Set unit’s Program Code

[5{r}]☎☎ Set Ring Count before auto answer

[6{d}]☎☎ Set Dial Mode‡

‡ Dial Mode

0 = Tone dial only

1 = Rotary dial only

2 = Tone dial with Secondary Relay pulse

3 = Rotary dial with Secondary Relay pulse

[7{x}]☎☎ Set Operation Mode, where x = :

1 = Standard Emergency mode

3 = Multiple HF-2’s share same phone line

4 = Ring Down Emergency mode (Seizes phone line, waits)

[8{lll}]☎☎ Set Call Length Time Limit

[9(tones)#] Echo Test.

[ 1 then 1-0] Verifies primary or backup telephone numbers

[#] Return to Normal Mode

