



---

**TABLE OF CONTENTS**

---

INTRODUCTION----- 3

PRODUCT OVERVIEW ----- 3

MOUNTING ----- 4

Backbox Dimensions ----- 4

WIRING ----- 4

Wiring Diagram----- 5

PROGRAMMING ----- 6

    Getting into programming mode ----- 6

    Programming entry codes ----- 6

    Deleting entry codes ----- 6

    Changing programming code ----- 6

    Programming time-of-day clock ----- 6

    Programming relay 1 “on” time/day ----- 6

    Programming relay 1 “off” time/day ----- 6

    Programming relay 2 “on” time/day ----- 7

    Programming relay 2 “off” time/day ----- 7

    Setting relay 1 cycle time ----- 7

    Setting relay 2 cycle time ----- 7

OPERATION----- 8

    Calling the Resident ----- 8

    Call waiting ----- 8

    Receiving a Call form the Gate----- 9

    Special Resident Operation ----- 9

    Gate Control mode ----- 9

    Trouble Shooting Guide ----- 10

## INTRODUCTION

This manual contains all the information required to successfully install and program the TRIGON CastleGate II. If you are using this manual to install this unit, it is very important for you to read all sections in order.

You should read these instructions before you begin this installation. This will insure correct installation.

If you are using this manual as a programming guide after the initial installation, you may find the TABLE OF CONTENTS useful in locating the particular programming procedure needed.

## PRODUCT OVERVIEW

The CastleGate II is a “No Phone Charge”, handsfree telephone entry system for use at a single residence. It uses the resident’s existing telephone line for communication and access control. Since gate calls do not go through the telephone company network, there are no charges for calls made from the system.

Visitors initiate calls from the entrance by pressing the “call” button on the illuminated faceplate. The call is received in the residence as with any other call. The resident can discern between entrance calls and regular telephone calls due to the unique ring modes available in the Castlegate II programming.

With up to 50 codes available, residents, employees, or guests can access the premises immediately by entering their personal entry code on the CastleGate II’s keypad (Fig. 1).

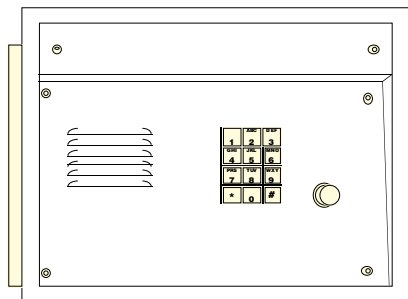
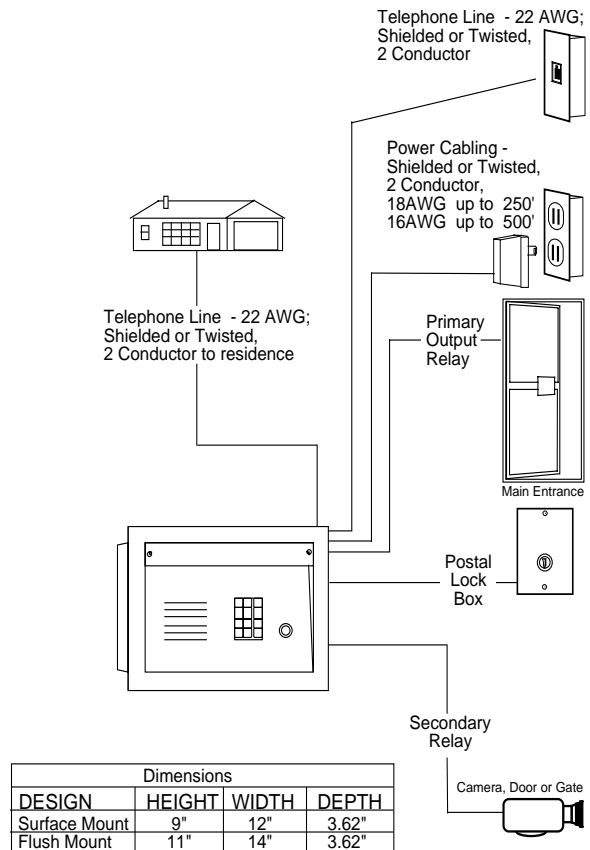

Figure 1



Hookup Specifications

## MOUNTING

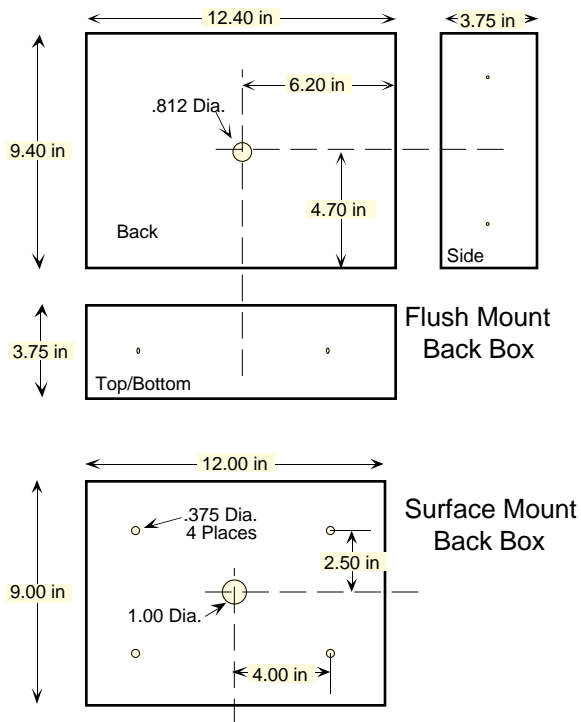

Figure 2

Use the appropriate Backbox drawing (Fig. 2) to prepare the surface on which the Trigon is to be mounted. The unit is designed to be as weather-resistant as possible. We do recommend shelter from direct rain and sunlight. An overhang is usually sufficient.

**For surface mount versions:** Bolt the backbox to the mounting surface using the four 5/16" holes in the chassis. Also, pull the wiring through the access hole in the rear of the backbox. At this point, the wiring should NOT be live (energized).

**For flush mount versions:** Use the flush version template for proper hole size to mount the backbox.

Make sure that if water is going to run down the wall, proper sealing precautions are taken to keep rain etc. from flowing into the unit. A small overhang is usually sufficient.

**WARNING:**

If a conduit is to be attached to the CastleGate II, be certain the conduit connector does not protrude more than 1/2" into the backbox. Any deeper penetration will contact the circuit board when the face plate is installed. If enough pressure is applied, the circuit board will be bowed and may contact other components causing erratic behavior.

## WIRING

1. Do not power any other device from the Trigon's 12 VAC transformer.
2. Do not energize wires until installation is completed.
3. Ground the unit by attaching a separate 12 AWG ground wire to the ground location on the terminal block (see wiring diagram Fig. 3). This ground wire should go to a grounding rod or grounded metal conduit.
4. Trigon recommends that an EMI filter (Cornell-Dubilier Model APF 1021 or equivalent) be mounted between the 12 VAC transformer output and the unit. EMI/RFI filters are available from Trigon. Mount the filter as close to the unit as possible. Ground the filter to the same point as unit ground. If using shielded cable, ground the shielding to the same point as the unit and filter. To avoid ground loops, do not ground the shield at both ends. Use 600V insulated wire for this installation.
5. Use 22 AWG wire on Telco / Resident line run distances of up to 2500 feet. Consult with the factory for distances greater than 2500 feet. If a substitute transformer is used, be sure it is rated 12 VAC, 20VA, U.L class 2 listed. The 12 VAC input power wires should be 18AWG, 600V, insulated wire. This should be sufficient for distances up to 200 feet.
6. Isolate the Telco phoneline in and the Resident phoneline out, from the 12 VAC power wires. This will prevent 60 Hz hum from occurring on the phoneline.
7. Use the enclosed wiring diagram (Fig. 3) for wire connection information. Be sure to hook up the memory battery.
8. Relays 1 and 2 are dry contact Form C type, rated for 5 AMPS @ 30 VDC/ 250VAC. A 3-wire harness is included to wire the relay outputs.
9. If all wiring and grounding is completed, mount the faceplate onto the backbox using the six "toolhead" fasteners provided.
10. Energize unit. You should hear one beep followed by four beeps if unit is new or if the battery was disconnected during a power failure. The four beeps mean the unit is initializing memory.

**Wiring Diagram**

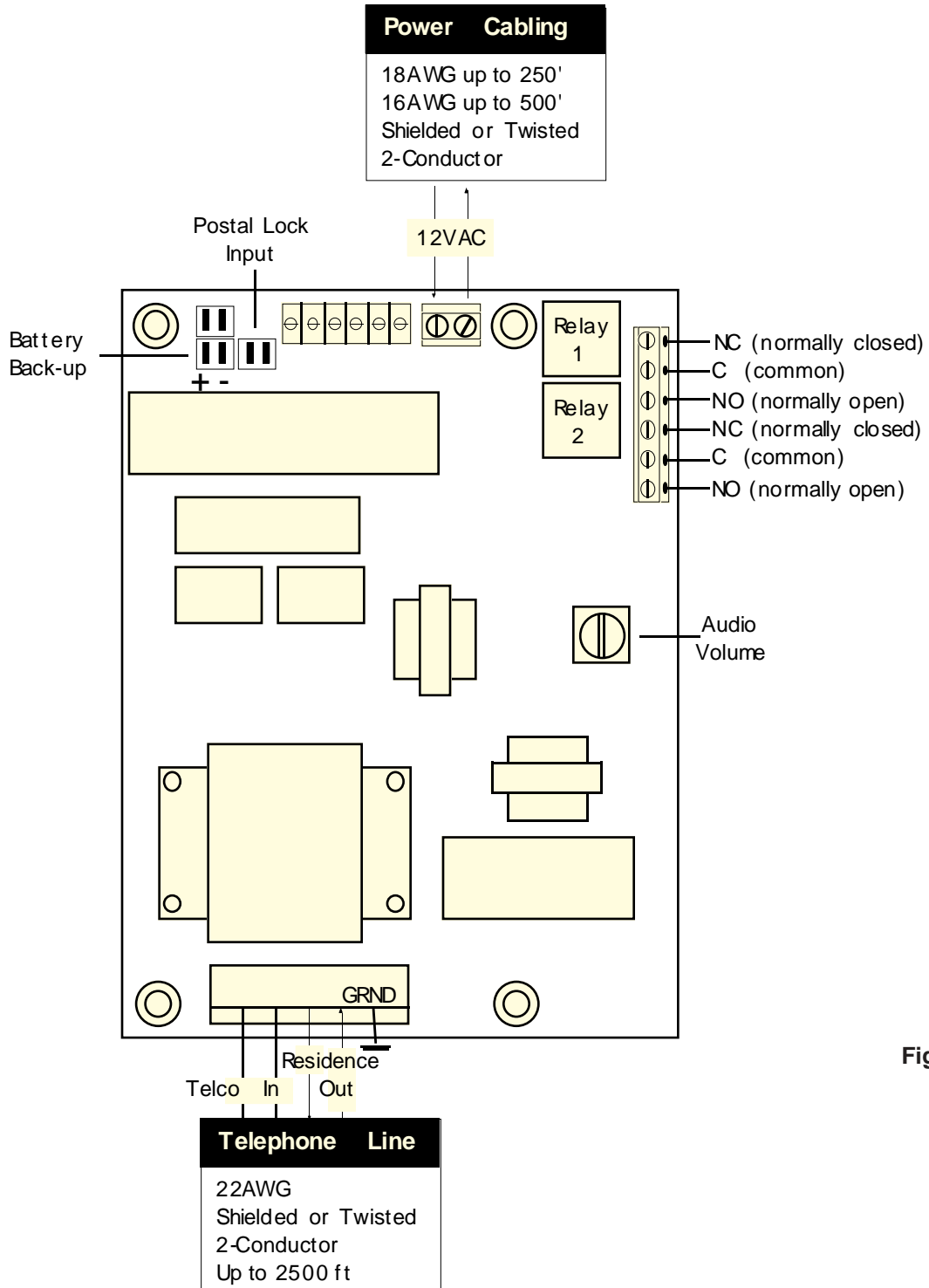

Figure 3

## PROGRAMMING

### Getting into programming mode:

#### A. Programming at the unit

Press the '\*' key followed by the Program Code (5269 if the unit is new). You will hear two 'beeps' indicating Program Code accepted.

#### B. Programming from the house

Lift your telephone's receiver and press 52 . You will hear three 'beeps' indicating Program Code accepted. Next press the '\*' key followed by the Program Code (5269 if the unit is new). You will hear two 'beeps' indicating Program Code accepted.

**Note:** When calling the gate, if the CastleGate II fails to answer by pressing 52 \* (or the new program access code you've set), press 00 \* to access it. If you find you must frequently use 00 \* to access your CastleGate II settings, please contact your installing dealer and ask him to contact the factory.

#### Programming Access Codes:

Entry codes make it possible for the user to enter a code at the unit and gain access. To program entry codes, the unit must be in programming mode.

Press "\* 1". You will hear one beep.

Enter the new 4-digit entry code. You will hear two 'beeps' (four 'beeps' indicate memory full).

Code number beginning with 1-4 will operate relay #1.

Code numbers beginning with 5-9 will operate relay #2. Numbers beginning with 0 will operate both relays. You will hear two beeps. If you hear four beeps here, memory is full (see deleting entry codes).

If you have multiple entry codes to input, simply enter the "\* 1" again and the second new code. Do this in like fashion until you are finished.

To exit the programming mode, press "\* \*".

#### Deleting Access Codes:

Unit must be in programming mode.

Enter "\* 4". You will hear one beep.

Enter the 4 digit access code that you want to delete. You will hear two beeps. Erasure is complete. If you hear four beeps here, the code entered was not in the memory.

Repeat steps 1 and 2 until all desired Access Codes have been erased

To exit programming mode, enter "\* \*".

#### Changing the Program code:

This feature allows the user to change the programming code to something other than the factory preset of 5269. The unit must be in programming mode.

Enter "\* 5". You will hear one beep.

Enter the new 4-digit programming code. You will hear two beeps. Keep in mind that the 5269 code (or any other previous code) is no longer valid. Keep good, safe record of your new programming code for future use.

Also note that Gate Control Mode is achieved by using the first 2 digits of the program code. If the program code is changed to "1234" then Gate Control Mode is achieved by tone dialing "12\*" from inside the house.

To exit programming mode, enter "\* \*".

**Note:** If, while performing this step, you lose the ability to access the programming mode, disconnect power from the unit. Disconnect the battery terminal on the circuit board for one minute (see wiring diagram in appendix).

Reconnect battery and restore power to the unit. The unit should beep once, and then four more times. The memory is now erased and the programming code is set back to 5269.

#### Programming time of day clock:

The time of day clock allows automatic operation of relays 1 and 2. The unit must be in programming mode to set the internal clock.

First, enter "\* 6". You will hear one beep.

Next, enter the hour. (military time; 00 - 23). To convert to military time, add 12 to the hour if in the P.M. For example, 3 P.M. = 15; 2 A.M. = 02.

Next, enter the minutes. (00-59)

Lastly, enter the day of week. (01-07 is Mon.-Sun.) After completing this step you should hear two beeps.

**Programming Relay 1 “on” time: PROGRAMMING cont.**

This feature allows time clock control of Relay 1. You may set the relay to activate at a certain time of day and deactivate at a later time. (NOTE: To program relay 1, do the following:

Unit must be in programming mode.

Enter “\* 7”. You will hear one beep.

Enter Start time. (military format; hours:minutes, i.e. “0630” , “1545”). Entry must be four digits.

Enter Begin-End Days. (1-7 is Mon. through Sun.). After completing this step, you should hear two beeps.

To exit the programming mode, press “\* \*”.

Example: “\*7 (beep) 06 30 15 (beep,beep)” This example would set relay 1 on at 6:30 AM Monday through Friday.

**Programming Relay 1 “off” time:**

Enter “\* 8”. You will hear one beep.

Enter end time: (military format; hours:minutes, i.e. “0630” , “1545”). Entry must be 4 digits.

Enter Begin-End days: (1-7 is Mon. through Sun.). After completing this step, you should hear two beeps.

To exit the programming mode, press “\* \*”.

**Programming Relay 2 “on” time:**

This feature allows time clock control of Relay 2. You may set the relay to activate at a certain time of day and deactivate at a later time. (NOTE: To program relay 2, do the following:

Enter “\* 9”. You will hear one beep.

Enter Start time. (military format; hours:minutes, i.e. “0630” , “1545”). Entry must be four digits.

Enter Begin-End Days. (1-7 is Mon. through Sun.). After completing this step, you should hear two beeps.

To exit the programming mode, press “\* \*”.

**Programming Relay 2 “off” time:**

Unit must be in programming mode.

Enter “\* 0” You will hear one beep.

Enter end time: (military format; hours:minutes, i.e. “0630” , “1545”). Entry must be 4 digits.

Enter Begin-End days: (1-7 is Mon. through Sun.). After completing this step, you should hear two beeps.

To exit the programming mode, press “\* \*”.

**Setting relay 1 cycle time:**

Cycle time is the duration of time the relay remains energized.

Relay 1 cycle time may be programmed to be from 00 to 99 seconds.

Enter “\* 2” You will hear one beep.

Enter gate time This is a two-digit number (00-99) that represents a time value from 00 to 99 seconds. After completing this step, you will hear two beeps.

**Setting relay 2 cycle time:**

Relay 2 cycle time may be programmed to be from 0 to 99 seconds.

Enter “\* 3” You will hear one beep.

Enter gate time This is a two-digit number (00-99) that represents a time value from 00 to 99 seconds. After completing this step, you will hear two beeps.

**Note:** Using 00 for a relay cycle time will disable that cycle timer.

**Note:** Using 01 for a relay cycle timer will only guarantee cycle period ranging from 0 to 1 second and may not produce an acceptable pulse. Use 02 seconds if a short pulse is the desired objective.

---

## OPERATION

---

### Calling the Resident:

A visitor simply presses the "call" button on the front of the CastleGate II to alert the resident to their presence. The unit then automatically rings the resident's telephone. When the call is received, the resident may grant entry by dialing "6" or "9" on their telephone. To deny entry, the resident simply hangs-up their telephone handset.

Residents may let themselves in by using a programmable 4-digit "keyless" entry code. Up to 50 such codes may be programmed into the CastleGate II. To avoid issuing keys, codes may be given to gardeners, pool maintenance personnel, and such. All codes can be easily voided.

Residents will know when a visitor is requesting entry, even if they are using their telephone at the time. A tone will notify them of an incoming call. They then press the "#" key on their telephone to put the outside call on hold. When the visitor at the gate has been granted or denied access, the resident can return to their outside call by again pressing the "#" key on their telephone.

**Note:** The following devices are connected to:

Relay #1 \_\_\_\_\_

Relay #2 \_\_\_\_\_

**Note:** Your Program

Access Code Is: \_\_\_\_\_

### Call waiting:

In the case where you are using your telephone when a call is initiated at the gate, you will hear a short tone in your handset every 3 seconds. To see who is at the gate without interrupting your call, press a '#' tone from a touchtone telephone. The person on the telephone with you will automatically be put on hold and you will be transferred to the visitor at the gate. After handling the gate call, you may switch back to your previous telephone conversation by pressing "0" or "#". If you hangup while someone is on hold or during an incoming call, the CastleGate II will alert you by ringing your telephone approximately 3 seconds later.

If you are talking to a visitor at the gate and you receive an incoming telephone call, you will hear a clicking sound in your handset. After handling the gate call, press the hookswitch momentarily to answer incoming telephone call.

OPERATION cont.

**Receiving a Call from the Gate:**

Answer telephone and identify visitor. Using your touchtone or rotary telephone keypad (Fig.4) , you have the following choices:

Press "6" to open door/gate attached to relay #1(close relay #1 for relay cycle time).

Press "9" to activate device attached to relay #2 (close relay #2 for relay cycle time).

"Hang up" to disconnect from gate call.

Press "#" to disconnect from gate and switch to Call Waiting.

**Note:** Press " 0" to disconnect from the gate and to obtain telephone company dial tone.

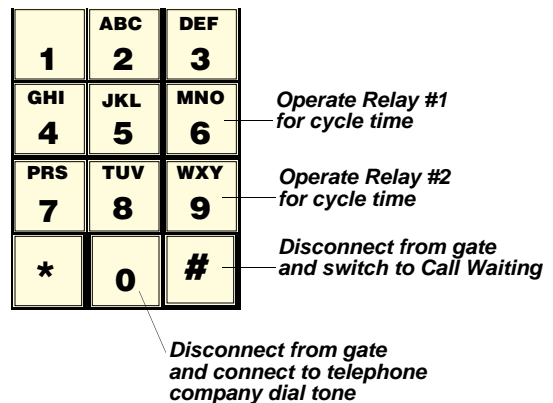

Figure 4

**Gate Control Mode:**

You may control the Castlegate II from inside your house. Lift your telephone's receiver.

Dial the first 2 digits of your program access code, followed by the "\*".

You will hear 3 beeps and be able to hear any activity near your gate.

Next use any of the tone commands below to control the system. Two beeps will acknowledge your choice to latch a relay. A single beep is the response to a release command.

Response to tones 6 and/or 9, will be a series of beeps until cycle times are completed.

**Special Resident Operation:**

Press "4" to latch open door or gate connected to relay #1.

Sends a continuous "open" command to the relay. Must be released by sending a "close" command. (see following)

Press "5" then hang up to release/close door or gate connected to relay #1 (Releases device only after telephone is hung up).

Press "7" to activate/latch device connected to relay #2.

Sends a continuous "open" command to the gate. Must be released by sending a "close" command. (see following)

Press "8" then hang up to deactivate/release device connected to relay #2 (Releases device only after telephone is hung up).

(Note)

You may press "5" to latch open the door or gate connected to relay #1, for the duration of the call. The door/gate will automatically close when the telephone is hung up.

You may press "8" to latch the secondary device connected to relay #2., for the duration of the call. The secondary device will be deactivated when the telephone is hung up.

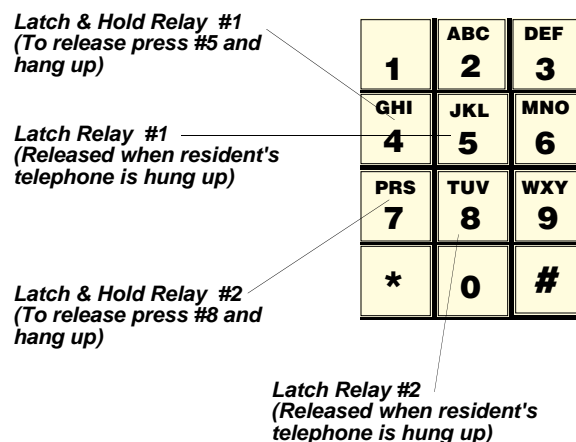

Figure 5

---

## TROUBLE SHOOTING GUIDE

---

### NO DIAL TONE

1. Check input power at unit. Should be 12 VAC. Check fuse.
2. Check that unit is properly grounded to a good Earth ground.
3. Current starved. Increase AC input wire size.
4. Remove power, wait 5 seconds, restore power. Check for dial tone.
5. Check for phone line. Should be 48-52 VDC across phone line terminals (on hook).
6. Check VOLUME adjustment on PC board.
7. Check "SPKR" plug on PC board. Make sure speaker is properly plugged in (Handsfree units).
8. Verify that contacts and wires are clean and tight.

### CANNOT PROGRAM

1. Incorrect/lost program code.
2. Not entering "\*" before program code.
3. Try 'NO DIAL TONE' troubleshooting procedures.
4. Keypad damaged. Check for vandalism.
5. Check that Program Prom/Microprocessor is fully seated.

### LOSES MEMORY

1. Electrical noise on power line. Install EMI/RFI filter.
2. Excessive electrical noise from strike. Use low current strike.
3. Unit transformer shared with another device (i.e. door strike).

### TENANT CANNOT ACTIVATE STRIKE/GATE

1. Tenant not pressing correct number on phone.
2. Strike/gate operator not wired correctly.
3. Missing or incorrect power to strike or gate operator.
4. Current starved. Increase wire size.
5. Tone may be too brief in duration (cordless phones, etc.).

### AC HUM IN EARPIECE/SPEAKER

1. Phone wires running in same conduit as AC power.
2. Unit not properly grounded.
3. Defective microphone.

### TENANT CANNOT HEAR VISITOR

1. Defective handset/microphone.
2. Too much background or street noise. Relocate unit.